

# MODEL 710

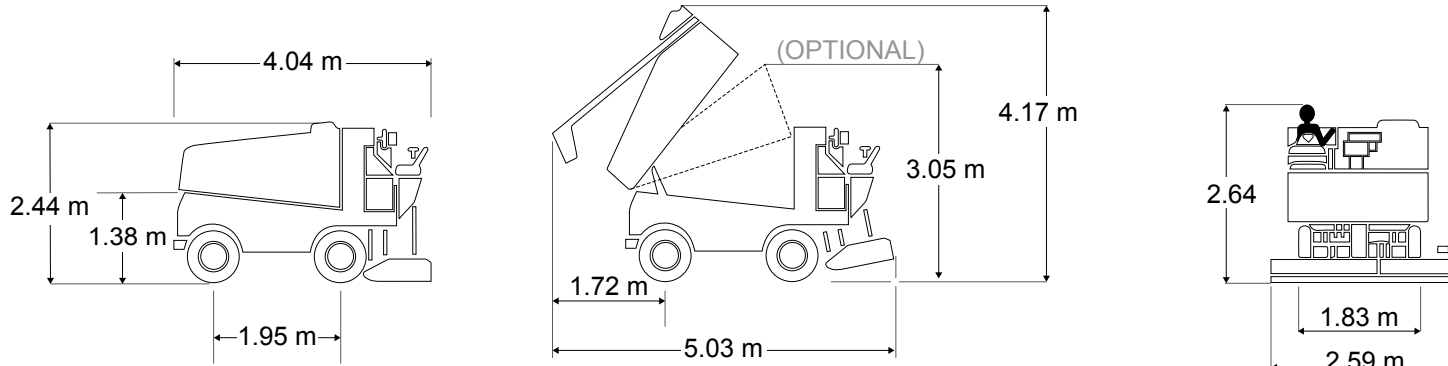

CAPACITIES		
<b>Snow Tank</b>		
Actual Volume	3.54 m <sup>3</sup>	125 cu. ft.
Compacted	4.53 m <sup>3</sup>	160 cu. ft.
Excess Water	662 L	175 gal.
<b>Water</b>		
Ice Making	1514 L	400 gal.
Wash Water	416 L	110 gal.
Total	1930 L	510 gal.
<b>Hydraulic Oil</b>	125 L	33 gal.
POWERTRAIN		
Four-Wheel Drive		
Engine	VM Motori® Industrial Diesel 3.0 L; Four Cylinder 79.2 kW / 106 HP at 2350 RPM EU Certified Engine	
Transmission	Continuously variable pump and motor are axial-piston type	
Hydraulics	Double pump powers the vertical and horizontal augers. Hydraulic down pressure for optimal resurfacing results.	
<b>Axles</b>	Rugged Dana Spicer® Model 70 Axles	
<b>Brakes</b>	Full Hydrodynamic Braking	

DIMENSIONS						
<b>Overall</b>	<b>L</b>	<b>W</b>	<b>H</b>	<b>L</b>	<b>W</b>	<b>H</b>
Snow Tank Down	4.04 m	2.59 m	2.44 m	159 in.	102 in.	96 in.
Snow Tank Up	5.03 m	2.59 m	4.17 m	198 in.	102 in.	164 in.
<b>Shaving Blade</b>	<b>L</b>	<b>W</b>	<b>H</b>	<b>L</b>	<b>W</b>	<b>H</b>
	243.8 cm	12.7 cm	1.27 cm	96 in.	5 in.	0.5 in.
<b>Clearance</b>						
Minimum Operator Height Clearance			264.2 cm			104 in.
Snow Pit Clearance			1.38 m			54.5 in.
<b>Conveyor System</b>						
Horizontal Auger Diameter			25.4 cm			10 in.
Vertical Auger Diameter			25.4 cm			10 in.
<b>Manueverability</b>						
Wheelbase			1.96 m			77 in.
Wheel Track			1.83 m			72 in.
Turning Radius at Conditioner			6.1 m			20 ft.
<b>Weight</b>						
Empty			4273 kg			9420 lb
with Water			6214 kg			13700 lb



### Galvanized Conditioner

Durable galvanized steel provides a scratch-free finish with protection from rust.

\*optional equipment



### Zamboni Power Brush™

Wider brush path reaches higher on the dasher board kick plate for superior cleaning

power. \*optional equipment



### Automatic Snow Breaker

Eliminates the need for manual control of the snow breaker by the machine operator.

\*optional equipment

**MODEL  
710**

## STANDARD FEATURES

2 Year Warranty  
400 Micron Wash Water Deep Filter Bag  
Aluminum Alloy Wheels  
Chassis: Strong All Welded Steel Tubing  
Conditioner Safety Guards  
Digital Training and Reference Materials  
Electronically Controlled Engine  
Engine: EU Certified  
Familiar Automobile-Style Foot Controls  
Four-Wheel Drive  
Fuel Tank: Large 100.7 L / 26.6 gal.  
Fuel: Diesel  
Full Hydrodynamic Braking  
Galvanized Steel Ice Making Water Tank  
Guide Wheel  
Headlights and Tail Light (for Off Ice Travel)  
High Quality 9 and 10 Micron Filters  
High Speed Vertical Auger  
Hydraulic Oil Level Sight Gauge

JIC Hydraulic Fittings  
Load Sensing Engine Governor  
Multi-Function Display  
On-Dash Diagnostics  
Parking Brake  
Power Steering  
Replaceable Poly Conditioner Side Plates  
Rugged Dana Spicer® Axles  
Snow Tank Safety Stand  
Spare Tire and Wheel  
Stainless Steel Hardware  
Steering Wheel Spinner Knob  
Touch-Up Paint Kit  
Tungsten Carbide Studed Tires  
Turbo Charged Inner Cooled Engine  
Under Seat Storage  
Wide Spectrum of Premium Automotive Paint Colors

## OPTIONS

Automatic Snow Breaker  
Back Up Alarm  
Cab Enclosure  
Conditioner: Galvanized  
Electric Water Level Gauge  
Hydraulic Oil Cooler Kit  
IceCaps® Wheel Advertising System  
Low Fuel Light  
Snow Melting Kit  
Snow Tank Dump Height Restriction  
Snow Tank Light  
Tire Wash System  
Wash Water to Ice Making Water Transfer  
[Zamboni Connect™ System](#)  
Zamboni Power Brush™ Board Brush System

**ZAMBONI**®

Some features described or shown may be optional at extra cost and prices, colors, materials, specifications and models are subject to change. Some options are required in combination with other options. ZAMBONI and the configuration of the Zamboni® ice resurfacing machine are registered trademarks of Frank J. Zamboni & Co., Inc. © Zamboni 2018

Rev 04/2018